



TOW-TRUST TOWBARS

Tow-Trust Towbars Technical Support
 Email - technical@tow-trust.co.uk
 Phone: 01827 717412 / WhatsApp: 07778 775135

In partnership with
 ConWysAG

PRO-PARK-PE-2 (For MY24 > Vehicles From VIN XXXXXXXXXRXXXXXX) Citroen Dispatch / Space Tourer, Peugeot Expert / Traveller, Toyota Proace / Proace Verso, Vauxhall Vivaro 01/2024 >

Part Number	PRO-PARK-PE-2	Document Number	TECPRO-PARK-PE-2	Issue Number	V1.1
Vehicle Make	See Above	Vehicle Model	See Above	Model Year	2024 >

Contents

Item	Description	QTY	Item	Description	QTY	Item	Description	QTY
 CON-22500761CR	6 x Extension cables 4 with Black Plugs 2 with Grey Plugs	6	 ASG-17027	Parking Sensor Carrier	4	 ASG-17028	Parking Sensor Bung	4
 DT-PRO-PARK	Drilling Template	1	 PRO-PARK-AN12	120* 4.8 Cable Tie Black	4	 PRO-PARK-AM10	100* 2.5 Cable Tie Black 100* 2.5 Cable Tie Yellow	12 12

Please note:

This PRO-PARK kit is ONLY suitable for MY24 > vehicles. (From VIN XXXXXXXXXRXXXXXX)

IMPORTANT: IF THE VEHICLE IS FITTED WITH BLIND SPOT SENSORS THEY MAY NEED TO BE RELOCATED INTO THE STEP USING THE 2 X GREY LOOMS

A PRO-STEP is NOT included and must be ordered separately.

A 27mm Hole Cutter is NOT included.

1



If required remove the bumper to gain access to the reversing sensors.

2



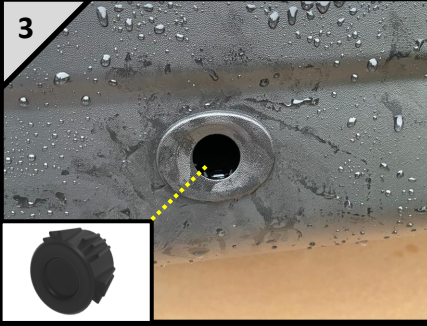

Remove the 4 OEM parking sensors from the rear bumper, leaving the carriers in the bumper.

3

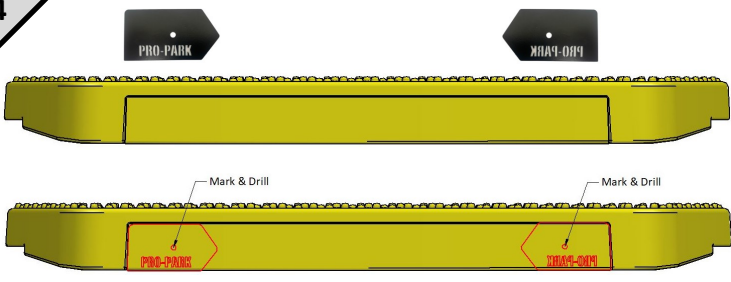

Insert the Parking sensor bungs into the OEM carriers to blank off the holes in place of the OEM Sensors. The bungs push in from the outside.

4

Drill Ø27mm holes

Using the DT-PRO-PARK drilling template place the template onto each step tread as shown above. Carefully mark and cut two 27mm holes for the carriers in each tread.





TOW-TRUST TOWBARS

Tow-Trust Towbars Technical Support

Email - technical@tow-trust.co.uk

Phone: 01827 717412 / WhatsApp: 07778 775135

In partnership with
ConWysAG

PRO-PARK-PE-2 (For MY24 > Vehicles From VIN XXXXXXXXXRXXXXXX)

Citroen Dispatch / Space Tourer, Peugeot Expert / Traveller, Toyota Proace / Proace Verso,

Part Number	PRO-PARK-PE-2	Document Number	TECPRO-PARK-PE-2	Issue Number	V1.1
Vehicle Make	See Above	Vehicle Model	See Above	Model Year	2024 >

5

Ensure the carriers are the correct orientation before fitting them to the step.

6

Insert the Tow-Trust carriers into the step treads pushing them in from the front.

7

Connect the extension cables to the OEM sensors.

8

Short Cable on the inner channel of the tread

Insert the OEM parking sensors into the parking sensor carriers ensuring the OEM sensors face outward in each tread and route the cables in the channels in the step.

8

Long Cable on the outer channel of the tread

9

PRO-PARK-AM10Y Shown

Secure the extension cables to the step using the appropriate 12 small cable ties.

10

Fit the PRO STEP in accordance with the fitting instructions supplied with the PRO-STEP.

11

Connect the parking sensor cables to the original vehicle parking sensor connectors and use the larger cable ties to secure in place.

12

Once the sensors have been installed test the sensors to ensure they work correctly.

IMPORTANT

Please ensure the PRO-STEP (not supplied) is fitted as per the installation instructions and all bolts are torqued to the correct torque setting.

We are always here to support you!

Call: 01827 717412

Email: technical@tow-trust.co.uk

WhatsApp: 07778775135

