



TAUT6VK-6224 Auto-Trail Excel Models 675B, 690L & 690T (Not 620G) 2023>, F-Line All Models F60, F62, F67, F68, F70, F72, F74 2019>, Roller Team Kronos Compact 590 (Skeletal Chassis Setting One) 2025> & Ford Skeletal Chassis Based Vehicles 2014>

Item	Qty	Description	Item	Qty	Description
A	1	TAUT6 Crossbar	H	1	Flip Up Socket Plate (TTFP/LH)
B	2	Side Arms	J	2	M12 x 25 Bolts & S/P Washers
C	4	19 mm O/D 52 mm Long Spacer Tubes	K	2	M12 x 22 Bolts & S/P Washers
D	4	19 mm O/D 60 mm Long Spacer Tubes	L	4	M12 x 45 Bolts & Nyloc Nuts
E	2	Chassis Spacer Plates	M	8	M12 x 90 Bolts & Nyloc Nuts
F	1	6#24 Detachable Neck	N	24	12 x 25 Flat Washers
			P	4	12 x 40 Flat Washers

Towbar Installation:

1. Remove the four fixings at the rearmost mounting points. (Auto-Trail Models F60/F62, these Models will not use item E).
2. Loosely attach items **B** to the inside face of each chassis, with items **E** as spacers at the rearmost mounting point on the skeletal chassis and fix in place using items **M** with items **N** and items **P** with items **C** and **D** inserted into the chassis. (Note: Items **C** are inserted through the ends of the chassis and items **D** through the side face). Using the locations shown in **Figures 1 to 4**.
3. Using items **L** with items **N** loosely fix item **A** to items **B**.
4. Using items **J** and items **K** with items **N** fix item **F** and item **H** to item **A** to the position shown in **Figures 1 & 2** for Auto-Trail & Roller Team Models, for other skeletal based vehicles use the setting best suited to the vehicle.
5. Fully tighten all fixings ensuring the Towbar is rigid, square, and secure.

Figure 1

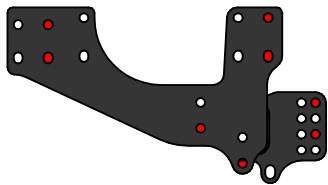

Auto-Trail F-Line Setting
F60 and F62

Figure 2

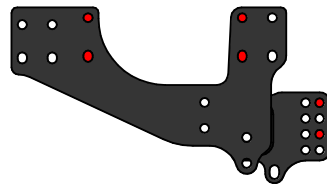

Setting For Use With
TAUT6-CSK Only

Figure 3

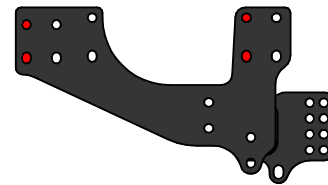

Skeletal Chassis
Setting One

Figure 4

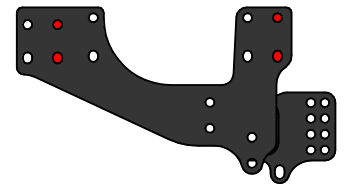

Skeletal Chassis
Setting Two

When Fitting To Models With Chassis Extensions, Order TAUT6-CSK In Addition For Full Installation

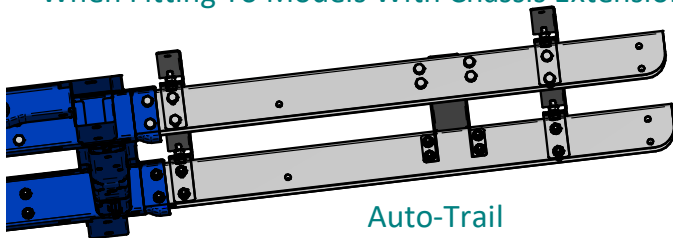

Auto-Trail
Bare Chassis

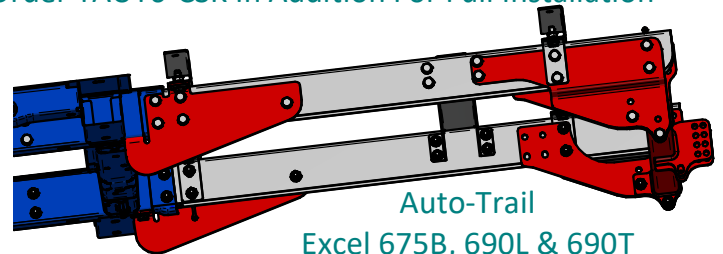

Auto-Trail
Excel 675B, 690L & 690T
F-Line F67/F68/F70/F72/F74

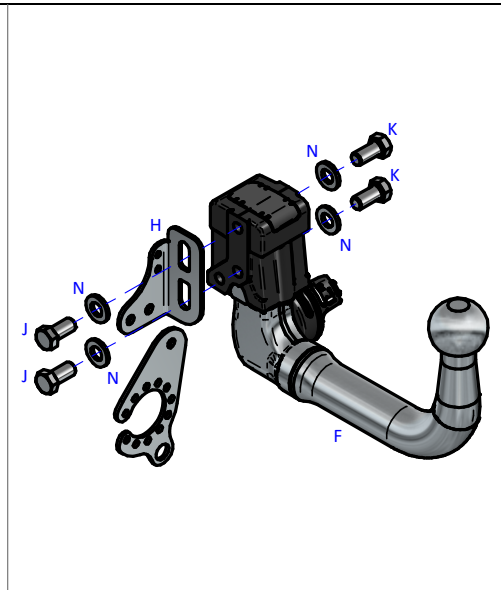
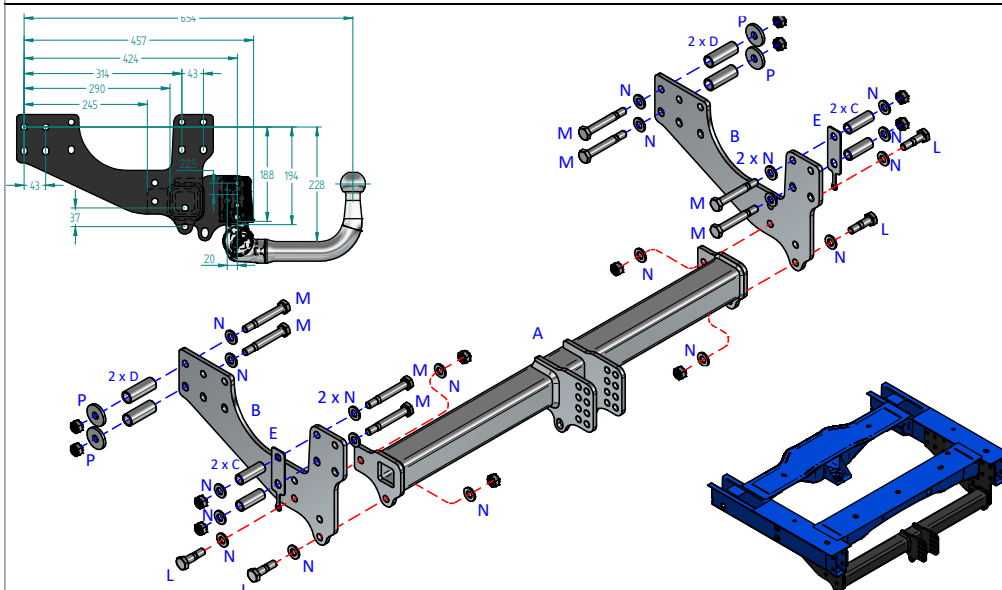

Notes:

1. For Torque settings see general notes overleaf.
2. Nose load limits and vehicle manufacturer's trailer / caravan weight limits must be observed.
3. We recommend the use of PRO-TOW Couplings with all our products.