



**TAUT8 Auto-Trail Tribute (Ford Based Only) T615 T620 T625 T715 T720 T725 Range Motorhomes
& Ford Based Internally Mounted Chassis Extensions With 145mm Hole Centres 826-834mm Internally Mounted 2006>**

Item	Qty	Description	Item	Qty	Description
A	1	TAUT8 Crossbar	H	2	M16 x 50 Bolts & Nyloc Nuts
B	2	Side Arms	J	2	M12 x 40 Bolts & Nyloc Nuts
C	4	22 mm O/D 44 mm Long Spacer Tubes	K	1	M12 x 120 Bolt (10.9) & Nyloc Nut
E	2	Chassis Spacer Plates	L	8	M12 x 45 Bolts & Nyloc Nuts
F	1	Extension	M	4	M12 x 90 Bolts & Nyloc Nuts
			N	28	12 x 25 Flat Washers
S	1	ASP5	P	4	12 x 40 Flat Washers
T	1	ATT—T1	T1	1	30 mm O/D 60 mm Long Spacer Tube

Notes:-

1. This Towbar can also be installed on Ford Chassis Extensions mounted to the inside face of the chassis using the 145mm mounting points.
2. **Page 1** is for Auto-Trail Tribute (Ford Based) models with OEM extensions **Figures 1 & 2** Show the correct settings for mounting this Towbar.
3. **Page 2** is for Ford Based Internally Mounted Chassis Extensions with 145mm hole centres.

Auto-Trail Towbar Installation:-

1. Using **Figure 1** identify the correct position to mount the Towbar.
2. Using **Figure 2** loosely fix items **B** to the inside face of each chassis extension using items **M** with items **N** with items **C** inserted into the chassis extensions and items **L** with items **N**.
3. Using items **L** with items **N** loosely fix item **A** to items **B** with items **E** in between as required.
4. Using items **J** with items **N** and item **K** with items **N** fix item **F** to item **A** to the position shown in **Figure 2**, ensuring item **T1** is fitted at the lower point.
5. Using item **H** fix item **S** and **T** to item **F** then fully tighten all fixings ensuring the Towbar is rigid, square, and secure.

Figure 1

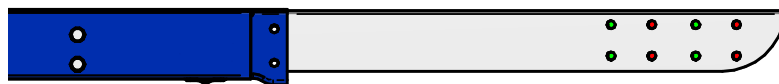

- T615, T620 & T625
- T715, T720 & T725

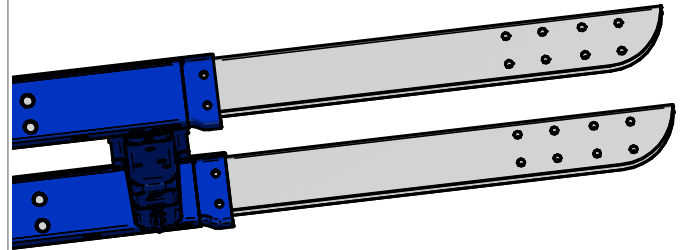
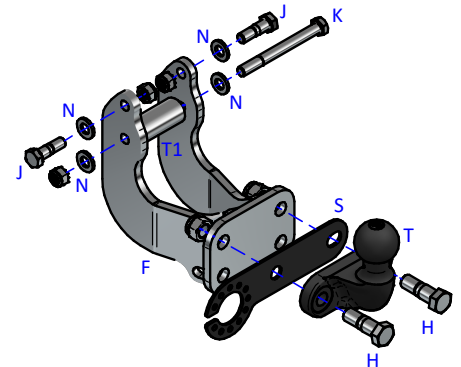
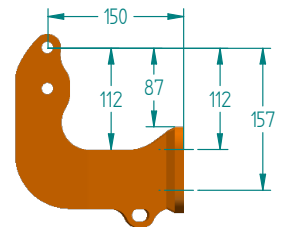
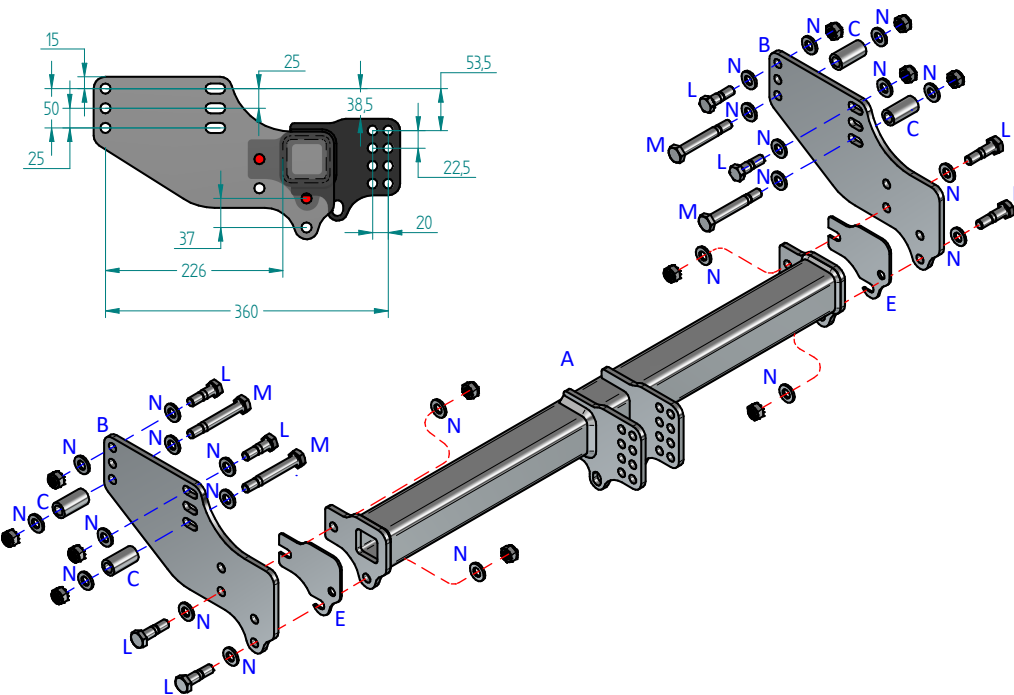
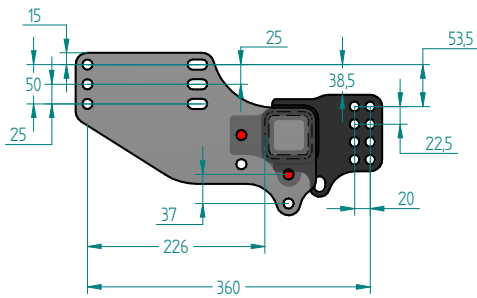
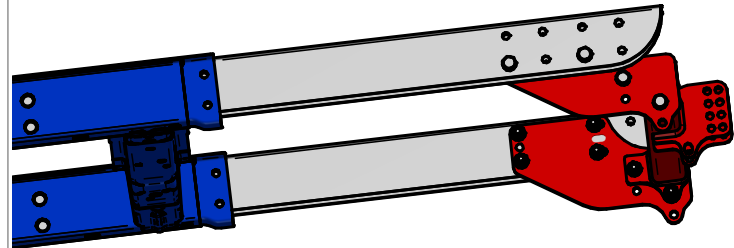
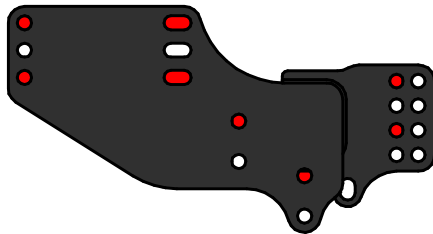

Figure 2



Notes:

1. For Torque settings see general notes overleaf.
2. Nose load limits and vehicle manufacturer's trailer / caravan weight limits must be observed.
3. We recommend the use of PRO-TOW Couplings with all our products.

Notes:-

1. This Page contains images and instructions only for mounting this Towbar to Ford Based Motorhomes with Chassis Extensions.
2. It is important that any Chassis Extensions fitted are check for suitability for towing and that there is a towing capacity before installation.
3. It is important that all dimensions are checked for suitability before purchase and fitment.
4. Some Chassis Extensions may require addition components before they become compatible with towing for example using **ATT-CHASS-CRS**.
5. **Figure 3** shows the chassis width and position the Towbar can be used with.
6. Items **M** and Items **C** are not used for this installation.

Towbar Installation:

1. Using **Figures 4, 5 & 6** identify the correct position to mount the Towbar.
2. Using **Figure 5** loosely fix items **B** to the outside face of each chassis extension using items **L** with items **N** and items **P** (on the inside face of the chassis).
3. Using items **L** with items **N** loosely fix item **A** to items **B** with items **E** in between as required.
4. Using items **J** with items **N** and item **K** with items **N** fix item **F** to item **A** to the position best suited to the vehicle, ensuring item **T1** is fitted at the lower point.
5. Using item **H** fix item **S** and **T** to item **F** then fully tighten all fixings ensuring the Towbar is rigid, square, and secure.

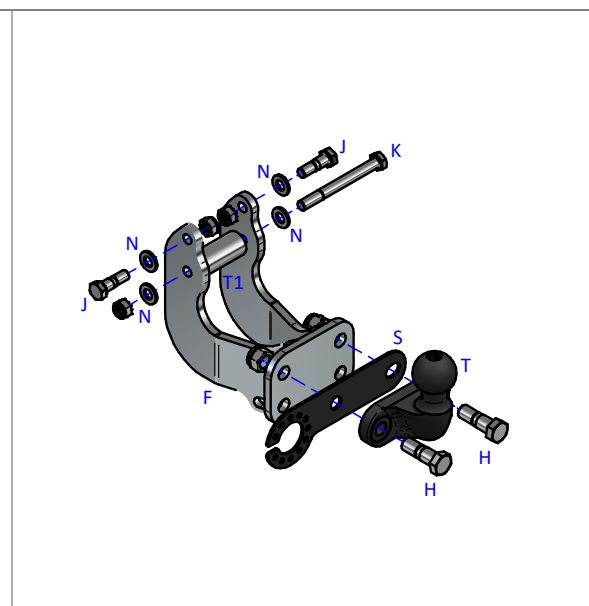
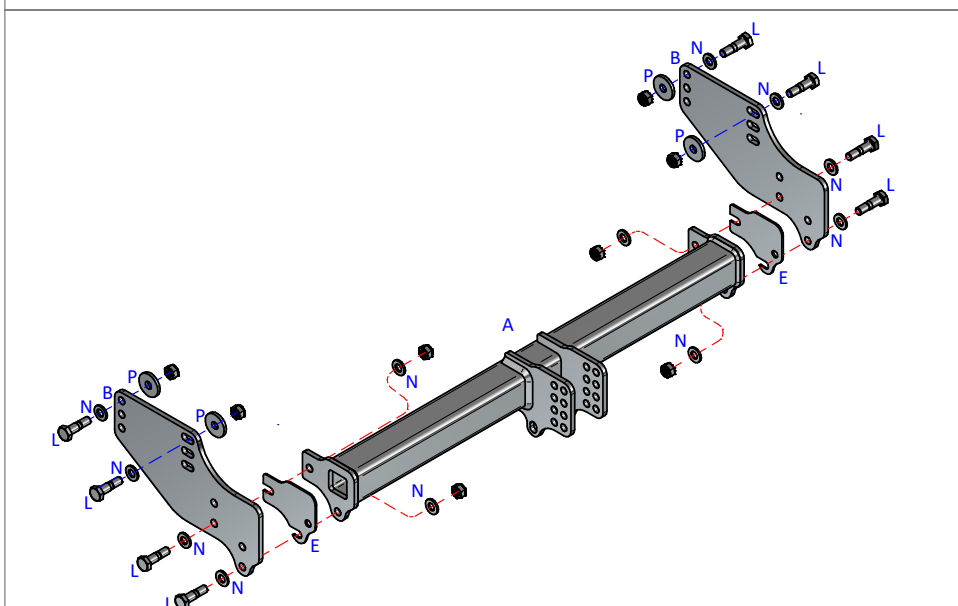
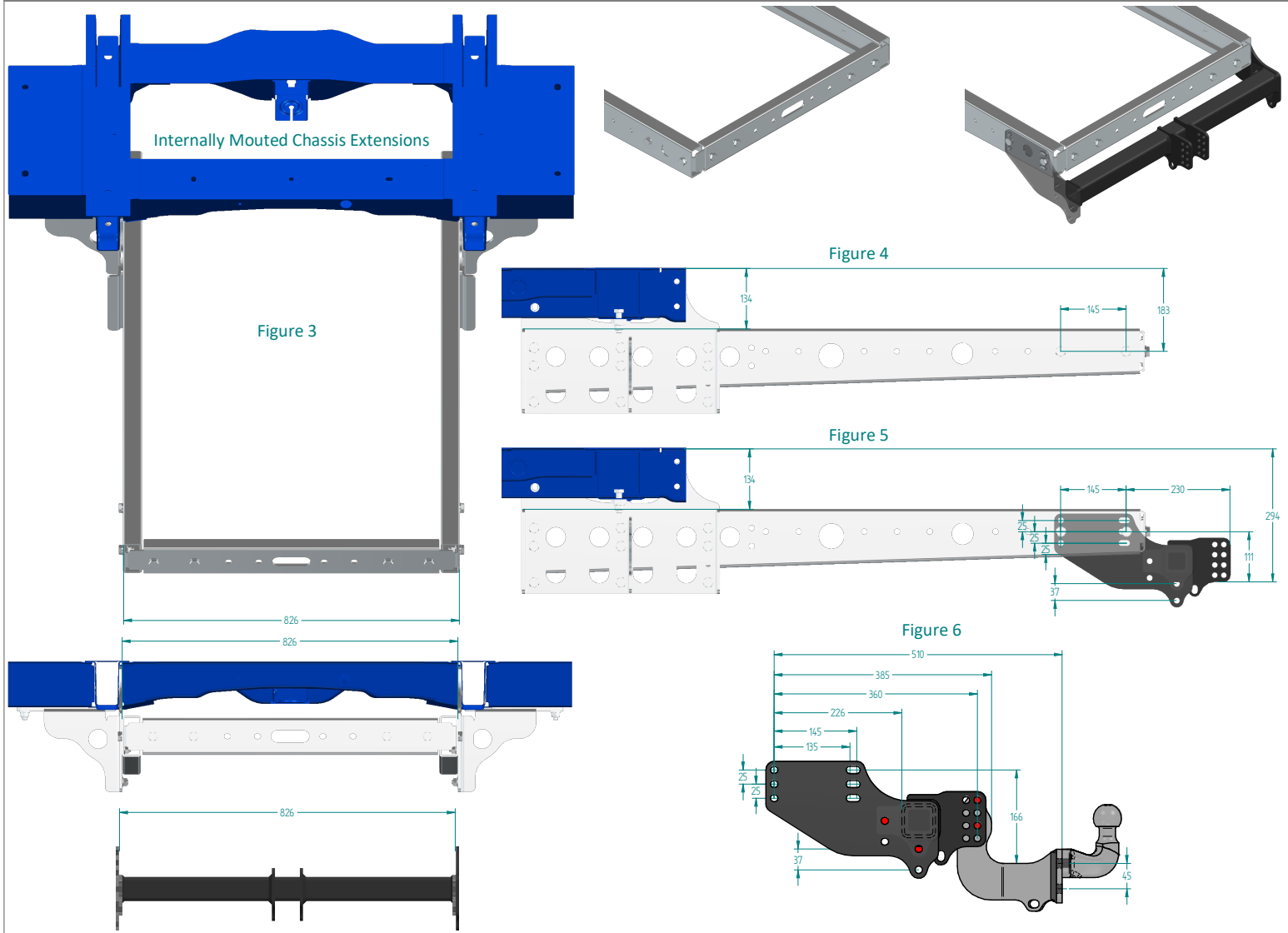

Notes:

1. For Torque settings see general notes overleaf.
2. Nose load limits and vehicle manufacturer's trailer / caravan weight limits must be observed.
3. We recommend the use of PRO-TOW Couplings with all our products