

TL249A Range Rover (L322) Not Sport Including Vogue & Overfinch 2002-2012

Item	Qty	Description	Item	Qty	Description
A	1	TL249A Crossbar	J	2	M16 x 55 Bolts & Nyloc Nuts
B	2	Bent Side Arms	K	1	M12 x 130 Bolt Grade (10.9) & Nyloc Nut
C1	1	Lefthand Side Arm	L	4	M12 x 45 Bolts Grade (10.9) & Nyloc Nuts
C2	1	Righthand Side Arm	M	4	M8 x 40 Bolts & Nyloc Nuts
D	2	Drop Plates	N	4	M12 x 30 Bolts & S/P Washers
E	2	Captive Clamp Plates	P	2	M14 x 160 x 1.5 (Fine Pitch) (10.9) Bolts & S/P Washers
F1	2	Exhaust Brackets 2006-2012	Q	2	M14 x 220 x 1.5 (Fine Pitch) (10.9) Bolts & S/P Washers
F2	4	Exhaust Spacers 2002-2006 (17 O/D x 12mm Long Tubes)	R	8	8 x 25 Flat Washers
G	1	TL249A Socket Plate	S	10	12 x 25 Flat Washers
H	1	TL249A Extension	T	4	14 x 27 Flat Washers
T1	1	60 O/D x 30mm Long Spacer Tube	U	10	M12 Bolts Caps

Preparation for towbar fitting and bumper removal:

1. Remove boot floor covering and rear trim.
2. Remove the rear mud flaps if fitted, then remove the tip screw and clips from each side.
3. Remove the four fixings from inside the boot on the rear panel.
4. Disconnect the reversing sensors from the right hand side in the boot.
5. Pull bumper out sideways and rearwards and fully remove.
6. Remove the left and right hand exhaust brackets. (2002-2006) two fixings each side, (2006-2012) one fixing each side and support.
7. Remove the two vertical towing eye fixings from each side and fully remove. (These are not refitted with the towbar).

Towbar Installation:

1. Locate items **D** onto the bumper studs and refit the bumper.
2. Loosely attach item **A** to items **D** with item **E** inserted into the end of the crossbar using items **N** with items **S**.
(Note:- Some models with Sport or Overfinch bumper may require a bumper cut).
3. Loosely attach items **F1** (2006-2012) with items **B** (Below the crossbar) and items **C1** and **C2** (Above the crossbar) using items **P** and items **T** at the forwardmost mounting points and items **Q** with items **T** at the rearmost mounting points.
4. Loosely attach item **H** with item **G** to item **A** using items **L** with items **S** and items **K** with items **S** ensuring item **T1** is fitted in-between. (As Shown Below)
5. Using items **J** fix your chosen ball bracket (Not supplied in this kit) to item **H** and fully tighten all fixings ensuring the towbar is rigid, square and secure.
6. Remount the exhaust to item **F1** (2006-2012) using the original fixings, or to items **C1** and **C2** using items **M** with items **R** with items **F2** as a spacer. (2002-2006).
7. Fully tighten the remaining fixings then fit items **U** over all **M12** fixings.

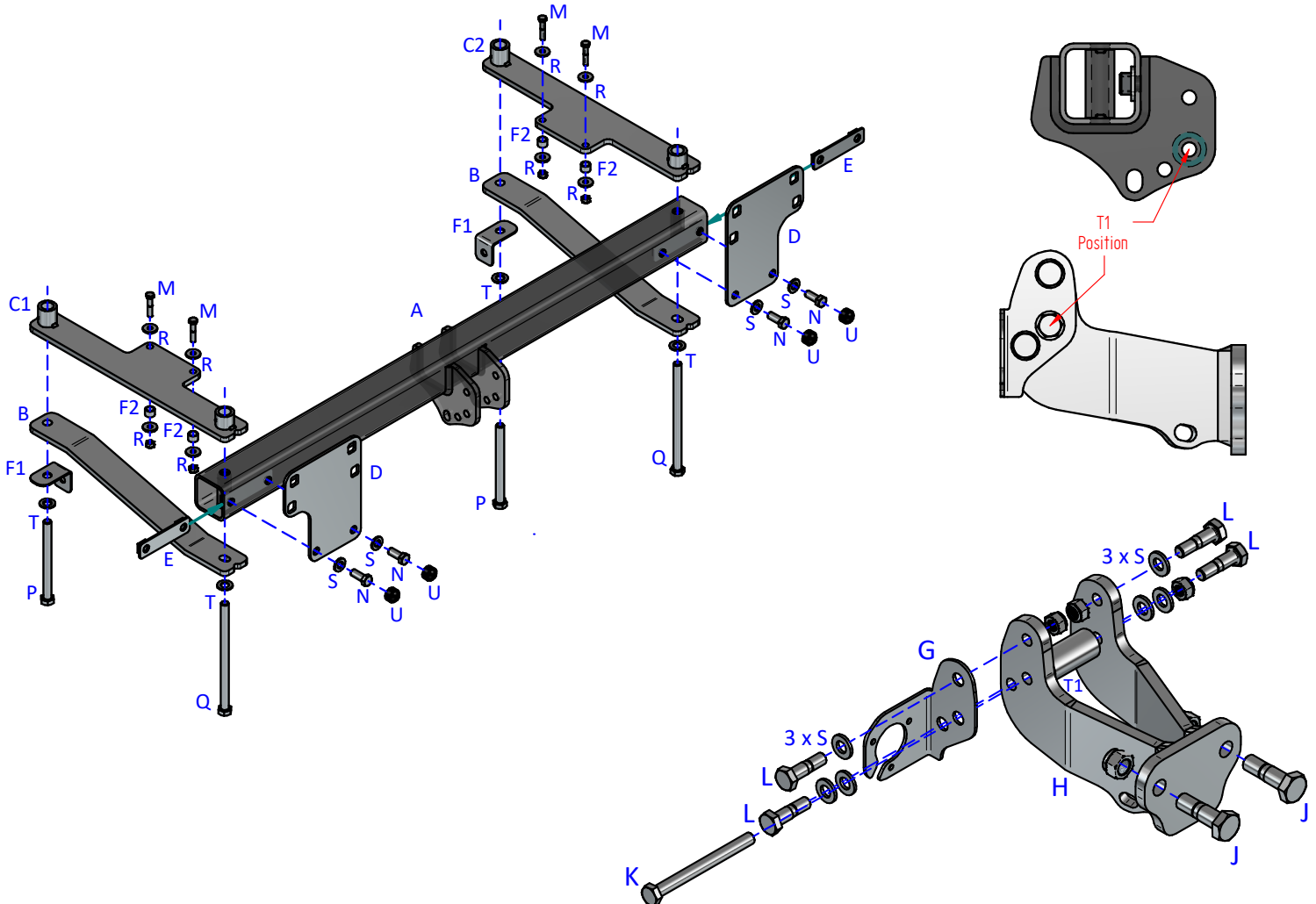

Notes:

1. For Torque settings see general notes overleaf.
2. Nose load limits and vehicle manufacturer's trailer / caravan weight limits must be observed.
3. We recommend the use of PRO-TOW Couplings with all our products.