



## TCH7 JEEP WRANGLER (JK) 2007 – 2018 & WRANGLER (JL) 2018>

Item	Qty	Description	Item	Qty	Description
A	1	TCH7 Channel	D	2	M16 x 50 Bolts, Nuts & S/P Washers
B	1	Extension Bar	E	4	M12 x 110 Bolts Grade 10.9, 2 Nyloc Nuts & 4 S/P Washers
C	1	Socket Plate	F	2	M12 x 40 Bolts Grade 10.9 & Nyloc Nuts
			G	2	M12 x 40 Bolts Grade 10.9 & Nyloc Nuts
			H	10	12 x 25 Flat Washers
			J	1	M8 x 25 Bolt & Nyloc Nut

### 2018> ONLY BUMPER REMOVAL:

1. Remove three fixings from the lower wheel arch trim each side, remove two fixings each side found behind trim.
2. Remove two fixings around each light cluster, located under the vehicle.
3. Remove two vertical fixings central to panel behind number plate.
4. Unplug the wiring loom and carefully remove the rear bumper.

### TOWBAR INSTALLATION:

1. **2007 – 2018:** Lower the exhaust silencer and support to prevent any damage, locate Towbar mounting points on rear crossmember of vehicle.
2. Using item F with item H and item G with item H loosely bolt item B to item A.
3. Using item E with item H bolt the Towbar assembly to the existing holes in the rear crossmember of the vehicle.
4. Using item D bolt the ball bracket (not supplied in this kit) to item B, using Item J bolt item C to item A and fully tighten all fixings ensuring the Towbar is rigid, square and secure.
5. Refit the exhaust silencer to hanger.
6. **2018>:** Remove the central bumper bracket from the rear crossmember and cut out the centre, SEE FIG.1.
7. Using item F with item H and item G with item H loosely bolt item B to item A.
8. Using item E with item H bolt the Towbar assembly to the existing central two holes in the rear crossmember of the vehicle.
9. Using the original fixings bolt the Towbar and the central original bumper bracket to the rear crossmember using the original fixings through the outer holes.
10. Using item D bolt the ball bracket (not supplied in this kit) to item B, using Item J bolt item C to item A and fully tighten all fixings ensuring the Towbar is rigid, square and secure.
11. Refit the rear bumper.

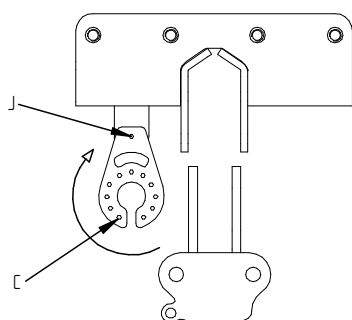
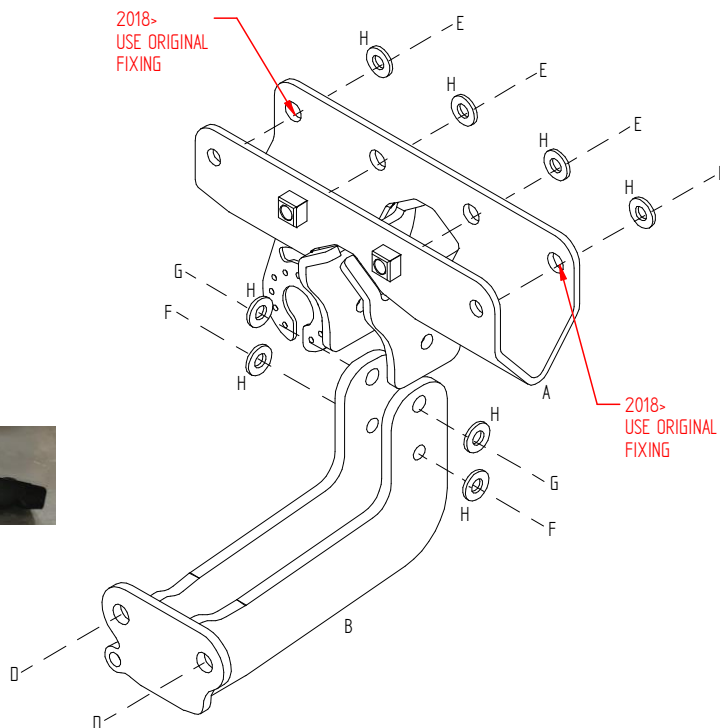

FIG.1 2018> ONLY, CUT OUT HATCHED AREA



### Notes:

1. For Torque settings see general notes overleaf.
2. Nose load limits and vehicle manufacturer's trailer / caravan weight limits must be observed.