



Tow-Trust Towbars

Important: Please read General Notes overleaf before fitting



Issue 3

TBM 911 BMW X3 2004 - 2011 (Inc. Sports Bumper)

Item	Qty	Description	Item	Qty	Description
A	1	Crossmember	C	2	M16 x 50 Bolts, Nuts & S/P Washers
B	1	Extension bar	D	2	M12 x 85 Grade 10.9 Bolts & Nyloc Nuts
			E	4	12 x 25 Flat Washers
			F	1	Socket Plate 1

1. Locate the cover in the centre of the bumper and remove (if fitted) cut out the marked area located on the raised plastic ridge inside the cover.
- 1A. Sports Bumper Models: Cut a section centrally from the lower edge 65mm wide x 125mm deep (if required trim to suit).
2. Remove rear bumper. Three fixings along lower edge, open boot hatch and remove covers from each corner on the top face of the bumper, this will reveal one fixing each side. Two fixings on wheel arch covers, two fixings inside wheel arch covers and one fixing at each bumper tip. Pull bumper rearwards and temporarily disconnect reversing sensors.
3. Remove bumper beam. (This is not refitted with the towbar.)
4. Using existing bumper beam nuts, bolt Item A into place and tighten to 71Nm. Note: It is recommended that some type of "thread lock" is used.
5. Refit bumper and reconnect reversing sensors.
6. Using Item D with Item E bolt Item B to Item A.
7. Using Item C bolt the ball bracket and wiring plate (not supplied in this kit) to the mounting plate

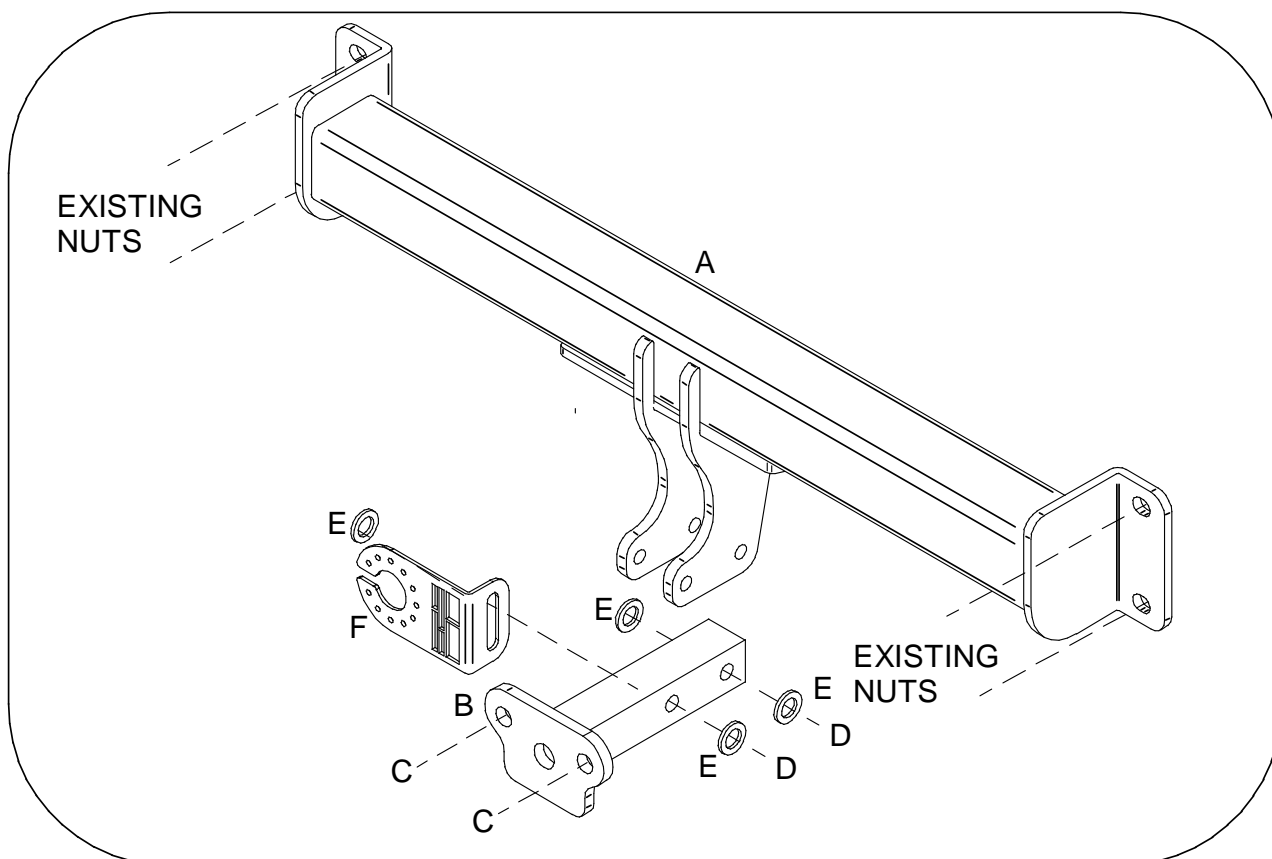

Note:

1. Recommended Torque Setting for M12 Grade 10.9 -139 Nm. (For other Torque Settings see notes overleaf.)
2. Nose load limits and vehicle manufacturers trailer / caravan weight limits must be observed.